



PYPLOK® TECHNICAL INFORMATION PACKAGE

Tube-Mac Industries Ltd.
853 Arvin Avenue
Stoney Creek, Ontario
CANADA L8E 5N8
(905) 643-8823

INDEX

Benefits of PYPLOK	3
Industries and Applications	6
PYPLPOK Pressure Ratings	7
Pipe/Tube Qualification for PYPLOK	8
Environmental Test Summary and Standards	9
Gas Leakage Test	10
Hydrostatic Proof and Burst Test	11
Impulse Test	12
Vibration Test.....	14
Impulse/Flexure and Fatigue at Low Temperature.....	16
Tensile Test	17
Torsion Test.....	18
Heat Aging Test	19
High Impact Shock Test (MIL-S-901D)	20
ISO 19921 Fire Test (2005 Ed.)	21
API 6FB (3 rd Ed.) Non-bending On-Shore or Open Offshore Fire Test	22
PYPLOK Qualification Test Report Listing.....	24



BENEFITS OF PYPLOK®

Product Line:

- **360° External Radial Swaged Fitting, designed and tested for over 30 years in the Aerospace Industry but now available in an Industrial Line of Products**
- **Permanent, tamper proof fitting ideal for rigorous and harsh applications that makes Hot Work Permits and Non-Destructive Testing redundant**
- **Proven Absolutely Leak-Free in many Marine High Pressure System Services (Military and Commercial applications)**
- **Completely Non-Welded Fitting Construction and light weight design**
- **One piece Fully Machined Fitting Body; No Sleeves or Rings producing a lighter weight fitting**
- **Up to 7000 PSI (4:1 Safety Factor) or 9300 PSI (3:1 Safety Factor) Allowable Working Pressure**
- **Complete Fitting Size Range ¼" thru 2" NPS, ¼" thru 2" OD Tube and 6mm thru 66mm Metric Tube in Carbon Steel, Stainless Steel, CuNi 70/30 and other materials**
- **Advanced Fitting End Configurations; Male & Female ORFS, JIC, SAE, BSPP and Others which can be installed using a standard hose crimp machine**
- **Cost Saving SAE Code 61 & SAE Code 62 Flange End Configuration Utilizes Interchangeable Fitting Body and Positional Flange**
- **Pyplok can be installed on imperfect Seamless, Hot Rolled or Welded pipe/tube with OD tolerances of:**

Metric Tube	+/- 0.254mm (0.010") 6mm thru 60mm
OD Tube	+/- 0.005" 1/4" thru 3/8", +/- 0.010" 1/2" thru 1 1/2"
NPS Pipe	+/- 0.015" 1/4" thru 1 1/2", +/- 0.030" 2" thru 3"

- **Expedient, Reliable, On-Time Product Delivery due to a large stock of standard couplings, elbows, tees and industry standard end configurations**
- **Fitting Seal To Pipe is achieved by Combined Metal to Metal, Primary O-ring (non-metallic) Seals and Back-up/Environmental Seals**
- **PYPLOK is the only fitting which has an internal environmental seal preventing sea water or other external factors from entering the fitting between the end of the fitting and the tube thereby eliminating corrosion issues in this area.**

- O-ring seal technology allows Pyplok to be installed on piping/tubing that has a less than perfect surface making the fitting ideal for maintenance jobs.

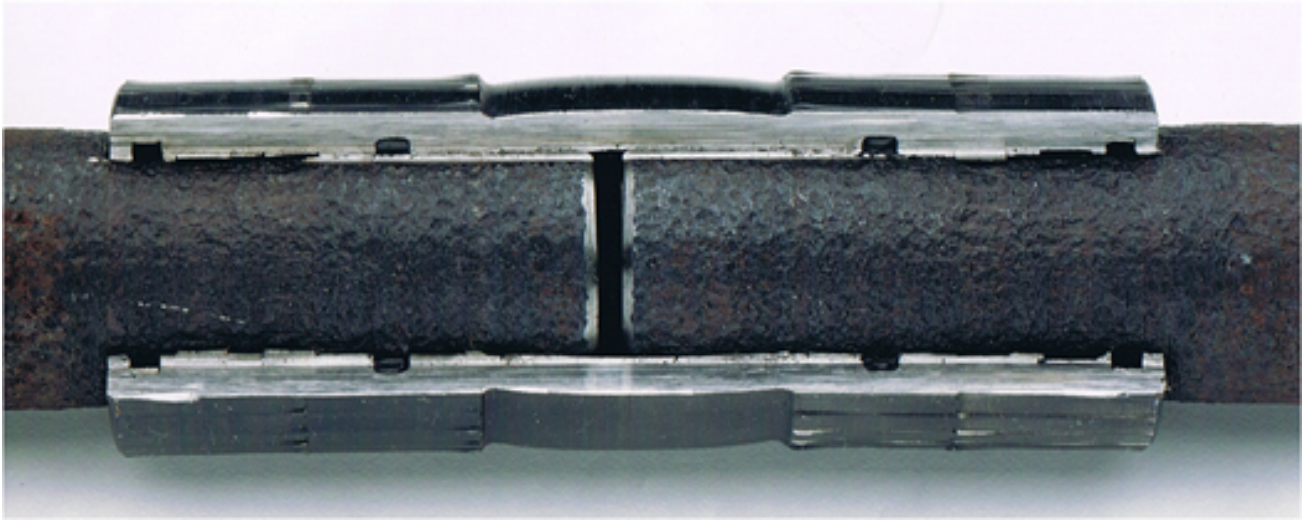

3/4" NPS Pipe-pitted due to years of exposure, Performed 6000 PSI Hydrostatic Proof Test and 1000 PSI Nitrogen Leak Test- No LEAKAGE DETECTED

Technical/Approvals:

- MIL 901 Rev B Shock Test, ISO 19921/15540 Fire Test, API 6FB Fire Test
- DNV, ABS, NAVSEA, USCG Acceptance, Canadian Coast Guard, Australian and New Zealand Navy
- (CRN) Canadian Registration No. 0A12153.5
- ASME B31.1, B31.3
- DNV Approval in Process (Expected June 2009)
- ISO 9001.2008 Corporation
- Extensive Record of qualification and proof testing from 1982 to present

Installation:

- Light Weight, Portable Tools to swage fittings in full size range, employing same swage dies for all materials types.
- Fittings can be Swaged multiple times with no possibility of over swaging due to a mechanical stop on the swaging tool.
- Installs on NPS Schedules 10-160, Metric tube with wall thickness greater than 0.80mm and OD Tube with wall thickness greater than 0.028"
- Installs on Imperfect Pipe/Tube Surfaces; Seamless, Hot Rolled or Welded
- Fitting can tolerate pipe ends cut up to 12°-15° Off Center

- No extra sealant or paste required on rough surface material
- New advancement in fitting range allows end connectors to be installed using a hose crimper machine and no investment in specialized tooling

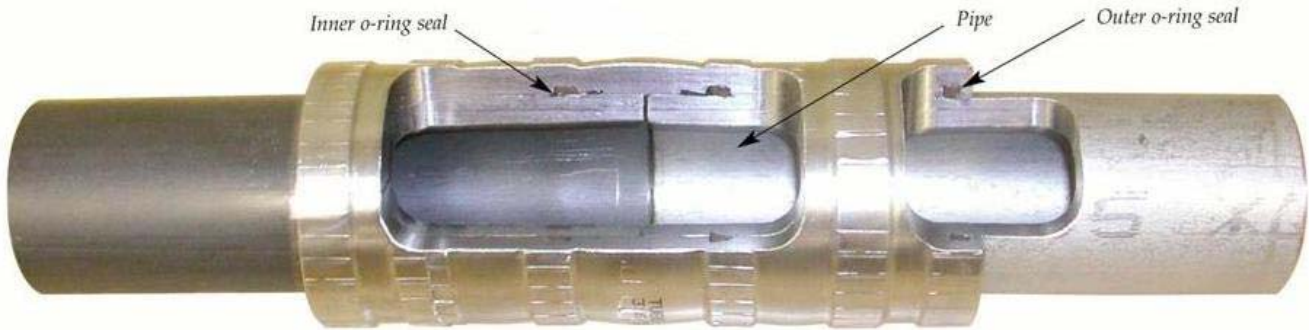

PYPLOK® FITTINGS can be used on stainless steel, copper nickel and carbon steel pipe or tube.



INDUSTRIES & APPLICATIONS

Pyelok has been used in numerous industries worldwide including but not limited to:

Ship Building and Repair (Commercial and Navy)

Refinery, Chemical, Pharmaceuticals, Food/Beverage

Marine, Offshore and Sub Sea

Land Based Drilling Rigs, Mobile Equipment

Sugar, Steel/Metal Production, Testing Equipment, Fire Suppression

Mining, Pulp and Paper, Nuclear/Power Generation

Pyelok Applications Include:

- **CNG – Compressed Natural Gas**
- **CO2 Cofferdam Inerting**
- **Condensate Piping**
- **Deluge Systems**
- **Down Well Coiled Tubing**
- **Drains and Plumbing Vent**
- **Ethylene Glycol/Water**
- **Fuel and Fuel Heating Lines**
- **Gases – Nitrogen, Air, Helium**
- **Heating Coils**
- **High Pressure Fire Suppression Systems**
- **Mobile Equipment Tubing/Piping**
- **High Pressure Hydraulics Systems**
- **Low Temperature Steam (<230°)**
- **LPG – Liquefied Petroleum Gas**
- **Lubrication & Grease**
- **Natural Gas Distribution**
- **Plant, Instrumentation and Utility Air**
- **RAD Waste Systems**
- **Solvents and Water Based Paints**
- **Subsea/BOP Piping**
- **Steam Tracer Lines**
- **Waste Water**
- **Numerous other applications**

Stainless Steel Pressure Ratings				
N.P.S Pipe	4:1 Safety Factor		3:1 Safety Factor	
	PSI	Bar	PSI	Bar
1/4"	6000	414	8000	552
3/8"	6000	414	8000	552
1/2"	5900	407	7866	543
3/4"	5800	400	7733	533
1"	5700	393	7600	524
1 1/4"	5650	390	7533	520
1 1/2"	5650	390	7533	520
2"	4800	331	6400	441
2 1/2"	338	23	451	31
3"	338	23	451	31
O.D. Tube	4:1 Safety Factor		3:1 Safety Factor	
	PSI	Bar	PSI	Bar
1/4"	7000	483	9333	644
3/8"	5800	400	7733	533
1/2"	6100	421	8133	561
5/8"	6100	421	8133	561
3/4"	6000	414	8000	552
1"	5800	400	7733	533
1 1/4"	5800	400	7733	533
1 1/2"	5650	390	7533	520
2"	4800	331	6400	441
Metric Tube	4:1 Safety Factor		3:1 Safety Factor	
	PSI	Bar	PSI	Bar
6mm	6500	448	8666	598
8mm	6200	428	8266	570
10mm	6000	414	8000	552
12mm	5800	400	7733	533
16mm	5800	400	7733	533
20mm	5650	390	7533	520
25mm	5650	390	7533	520
30mm	5650	390	7533	520
38mm	5650	390	7533	520
42mm	5650	390	7533	520
50mm	5100	352	6800	469
60mm	4800	331	6400	441
56mm	4500	310	6000	414
66mm	4130	285	5507	380

Carbon Steel Pressure Ratings				
N.P.S Pipe	4:1 Safety Factor		3:1 Safety Factor	
	PSI	Bar	PSI	Bar
1/4"	5000	345	6667	460
3/8"	5000	345	6667	460
1/2"	4917	339	6555	452
3/4"	4833	333	6444	444
1"	4750	328	6333	437
1 1/4"	4708	325	6278	433
1 1/2"	4708	325	6278	433
2"	4000	276	5333	368
2 1/2"	338	23	451	31
3"	338	23	451	31
O.D. Tube	4:1 Safety Factor		3:1 Safety Factor	
	PSI	Bar	PSI	Bar
1/4"	5833	402	7778	536
3/8"	4833	333	6444	444
1/2"	5083	351	6778	467
5/8"	5083	351	6778	467
3/4"	5000	345	6667	460
1"	4833	333	6444	444
1 1/4"	4833	333	6444	444
1 1/2"	4708	325	6278	433
2"	4000	276	5333	368
Metric Tube	4:1 Safety Factor		3:1 Safety Factor	
	PSI	Bar	PSI	Bar
6mm	5417	374	7222	498
8mm	5167	356	6889	475
10mm	5000	345	6667	460
12mm	4833	333	6444	444
16mm	4833	333	6444	444
20mm	4708	325	6278	433
25mm	4708	325	6278	433
30mm	4708	325	6278	433
38mm	4708	325	6278	433
42mm	4708	325	6278	433
50mm	4250	293	5667	391
60mm	4000	276	5333	368
56mm	3750	259	5000	345
66mm	3442	237	4589	316

CuNi 70/30 Pressure Ratings				
N.P.S Pipe	4:1 Safety Factor		3:1 Safety Factor	
	PSI	Bar	PSI	Bar
1/4"	3896	269	5195	358
3/8"	3896	269	5195	358
1/2"	3831	264	5108	352
3/4"	3766	260	5022	346
1"	3701	255	4935	340
1 1/4"	3669	253	4892	337
1 1/2"	3669	253	4892	337
2"	3117	215	4156	287
2 1/2"	188	13	250	17
3"	188	13	250	17
O.D. Tube	4:1 Safety Factor		3:1 Safety Factor	
	PSI	Bar	PSI	Bar
1/4"	4545	313	6060	418
3/8"	3766	260	5022	346
1/2"	3961	273	5281	364
5/8"	3961	273	5281	364
3/4"	3896	269	5195	358
1"	3766	260	5022	346
1 1/4"	3766	260	5022	346
1 1/2"	3669	253	4892	337
2"	3117	215	4156	287
Metric Tube	4:1 Safety Factor		3:1 Safety Factor	
	PSI	Bar	PSI	Bar
6mm	4221	291	5628	388
8mm	4026	278	5368	370
10mm	3896	269	5195	358
12mm	3766	260	5022	346
16mm	3766	260	5022	346
20mm	3669	253	4892	337
25mm	3669	253	4892	337
30mm	3669	253	4892	337
38mm	3669	253	4892	337
42mm	3669	253	4892	337
44.5mm	600	41	800	55
50mm	3312	228	4415	305
57mm	600	41	800	55
60mm	3117	215	287	4156
56mm	2922	202	269	3896
66mm	2682	185	247	3576

NOTE: Pressure Ratings are based on system Temperatures of -65°F to 400°F (-54°C to 205°C) and are limited to the maximum rating of the adjoining tube and or end connection

PYPLOK TUBE AND PIPE QUALIFICATION



WWW.PYPLOK.COM

OD TUBE		
Size	Min. Wall	Max Wall
1/4"	0.028"	0.083"
3/8"	0.028"	0.095"
1/2"	0.035"	0.120"
5/8"	0.035"	0.120"
3/4"	0.049"	0.180"
1"	0.049"	0.180"
1 1/4"	0.065"	0.220"
1 1/2"	0.065"	0.220"
2"	0.083"	0.220"

Metric Tube		
Size	Min. Wall	Max Wall
6	0.8mm	2.0mm
10	0.8mm	2.5mm
12	1.0mm	3.0mm
16	1.0mm	3.0mm
20	1.0mm	4.0mm
25	1.0mm	4.0mm
30	1.2mm	5.0mm
38	1.5mm	6.0mm
42	1.5mm	6.0mm
44.5	1.0mm	4.0mm
50	1.5mm	7.0mm
57	1.0mm	4.0mm
60	2mm	8.0mm

NPS		
Size	Min. Wall	Max Wall
1/4"	Sch.10	Sch.80
3/8"	Sch.10	Sch.80
1/2"	Sch.10	Sch.80
3/4"	Sch.10	Sch.160
1"	Sch.10	Sch.160
1 1/4"	Sch.10	Sch.160
1 1/2"	Sch.10	Sch.160
2"	Sch.10	Sch.160
2 1/2"	Sch.10	Sch.80
3"	Sch.10	Sch.80

Qualified Pipe/Tube
<u>Carbon Steel PYPLOK</u> ASTM A106/A53S ASTM A53E/A587 ASTM A179 DIN 2391c Gr.37.4 (E235+N) A135 ERW Grade A & B API 5L Seamless/Electric Weld MIL-T-20157
<u>Stainless Steel PYPLOK</u> ASTM A312 ASTM A269 (EN 10216-5) Types 304/304L/316/316L MIL-P-1144 DIN 2391c Gr.52.4 (E355+N) EN10217-7 (DIN 17457) EN ISO 1127 (D3 and D4)
<u>Copper Nickel PYPLOK</u> ASTM B280 ASTM B75 MIL-T-16420 CuNi 90/10 CuNi 70/30 MIL-T-24107

Note: As there are numerous pipe/tube specs not every spec has been listed. If you do not see your spec please consult the factory to confirm pipe/tube qualification.

Allowable Outside Pipe/Tube Diameter Tolerances for PYPLOK		
Metric Tube	6mm thru 60mm	+/- 0.254mm (0.010")
OD Tube	1/4" thru 3/8"	+/- 0.005" (0.127mm)
	1/2" thru 1 1/2"	+/- 0.010" (0.254mm)
	2"	+/- 0.015" (0.381mm)
NPS Pipe	1/4" thru 1 1/2"	+/- 0.015" (0.381mm)
	2" thru 3"	+/- 0.030" (0.762mm)

ENVIRONMENTAL TEST SUMMARY AND STANDARDS

PYPLOK APPROVALS & STANDARDS

- ISO 9001:2008 Certified
- ANSI/ASME B31.1 and B31.3
- ANSI/ASME B31.4
- ANSI/ASME B31.8
- (CRN) Canadian Registration No. 0A12153.5
- API 6FB Third Edition Nov.98 Fire Test for end connection fittings
- ISO 19921 Fire Test, Fire resistance of metallic pipe components with resilient and elastomeric seals.
- NAVSEA - United States Naval Sea Systems Command
- ANZAC - Australian, New Zealand Navy
- US Coast Guard
- Canadian Coast Guard
- ABS - American Bureau of Shipping
- DNV - Det Norske Veritas
- US Military Navy Shock Test MIL-S-901D

PYPLOK Fitting TEST SUMMARY

TEST	REQUIREMENTS	RESULTS
Gas Leak Test	Gn2 Nitrogen 1,000 PSI for 10 minutes	No leakage
Hydrostatic Burst	Based on 4 x Operating Pressure held for 5 minutes	No leakage
Hydrostatic Proof	Based on 1.5 x Operating Pressure held for 5 minutes	No leakage
Vibration Test	20,000,000 cycles at displacement @ operating pressure	Passed
Impulse Test	500,000 cycles @ 1.33 x Operating Pressure based on ISO/BS Impulse Cycle	Passed
Impulse/Flexure and Fatigue at Low Temperature	Simultaneous impulse and bending stress, 8 times during test of 10,000 cycles each under peak pressure and rated bending each fitting was subjected to -100 deg F for one hour utilizing liquid CO2.	No leakage
Tensile Test	Fitting was installed in tensile machine with cross head speed of 0.20 in/min and pulled until one side of pipe dismembered from the fitting/pipe joint	Exceeded Tensile Strength by a factor of 1.33 to 1.63
Torsion Test	At various Torsion Angles and Ft-Lbs of Torque @4500 Psig (Gn2) and 6000 Psig (Hydraulic Fluid)	No Leakage
Heat Aging	Maintained at 400 deg F ± 5 deg F for 168 hours, Proof test @ 6000 Psig for 30 minutes	Passed

Gas Leakage Test

Test Report Number	MCD-1124 and MCD-1127 ¹ (Qualification and Certification of Pyplok)
Laboratory	Deutsch Engineering Laboratory ²
Witnesses	Portions of tests were witnessed by NAVSEA and Long Beach Naval Shipyard Personnel
Test Parameters	Pyplok Test Sample was Pressurized to 100 PSI for 5 Minutes and then 4500 PSI for 5 Minutes with Gn ₂ Nitrogen Gas

Test Results

Size	100 PSI Gn ₂ Nitrogen Gas	4500 PSI Gn ₂ Nitrogen Gas	Remarks
1/4"	5 Minutes	5 Minutes	Pass, No Leakage
3/4"	5 Minutes	5 Minutes	Pass, No Leakage
1 1/2"	5 Minutes	5 Minutes	Pass, No Leakage

¹ Please consult factory for a copy of the report noted

² Accredited Lab by NADCAP AS7114 for NDT and Performance Review Institute ISO/IEC 17025 (www.dmcusa.com/aero/supplier-accreditations.lasso)

Hydrostatic Proof and Burst Test

Test Report Number	DMC-1499 ³ (Proof and Burst Test on DM series Pyplok)
Laboratory	Deutsch Engineering Laboratory ⁴
Test Parameters	<p><u>Proof Test:</u></p> <p>Pyplok Test Samples were Pressurized to 1000 PSI for 5 Minutes and then 5000 PSI for 5 Minutes and then 15 000 PSI for 5 minutes using Mil-H-5606 Hydraulic Oil</p> <p><u>Burst Test:</u></p> <p>After successful completion of the Proof test each sample was subjected to gradual increased pressure until failure occurs</p>

Test Results:

Size	Proof Test (1000, 5000 and 15 000 PSI)	Actual Burst Pressure	Failure Mode	Remarks
1/4"	PASS	26 000 PSI / 1793 Bar	Fitting Failed	Exceed Test Requirements
3/8"	PASS	29 000 PSI / 2000 Bar	Fitting Failed	Exceed Test Requirements
1/2"	PASS	25 200 PSI / 1738 Bar	Pipe Failed	Exceed Test Requirements
3/4"	PASS	25 400 PSI / 1751 Bar	Pipe Failed	Exceed Test Requirements
1"	PASS	28 000 PSI / 1931 bar	Pipe Failed	Exceed Test Requirements
1 1/4"	PASS	17 500 PSI / 1207 Bar	Pipe Failed	Exceed Test Requirements
1 1/2"	PASS	24 000 PSI / 1655 Bar	Pipe Failed	Exceed Test Requirements
2"	PASS	15 100 PSI / 1040 Bar	Pipe Failed	Exceed Test Requirements

³ Please consult factory for a copy of the report noted

⁴ Accredited Lab by NADCAP AS7114 for NDT and Performance Review Institute ISO/IEC 17025 (www.dmcusa.com/aero/supplier-accreditations.lasso)

Impulse Test

Test Report Number	TMI-007 ⁵ (DNV Type Approval Qualification Testing)
Laboratory	Stork Garwood Laboratories Inc. ⁶
Test Parameters	<p>-Test samples are connected to a hydraulic pressure impulse rig and applied pressure impulse to the assembly at between 0.5 Hz and 1.7 Hz (30 cycles/minutes to 100 cycles/minutes) as per ISO/BS impulse cycle (See Fig.1)</p> <p>-The impulse test pressure is equal to 1.33 times designed maximum operating pressure of the fitting</p> <p>-Each sample impulses for a minimum of 5×10^5 cycles (500 500 cycles)</p>

Fig.1:

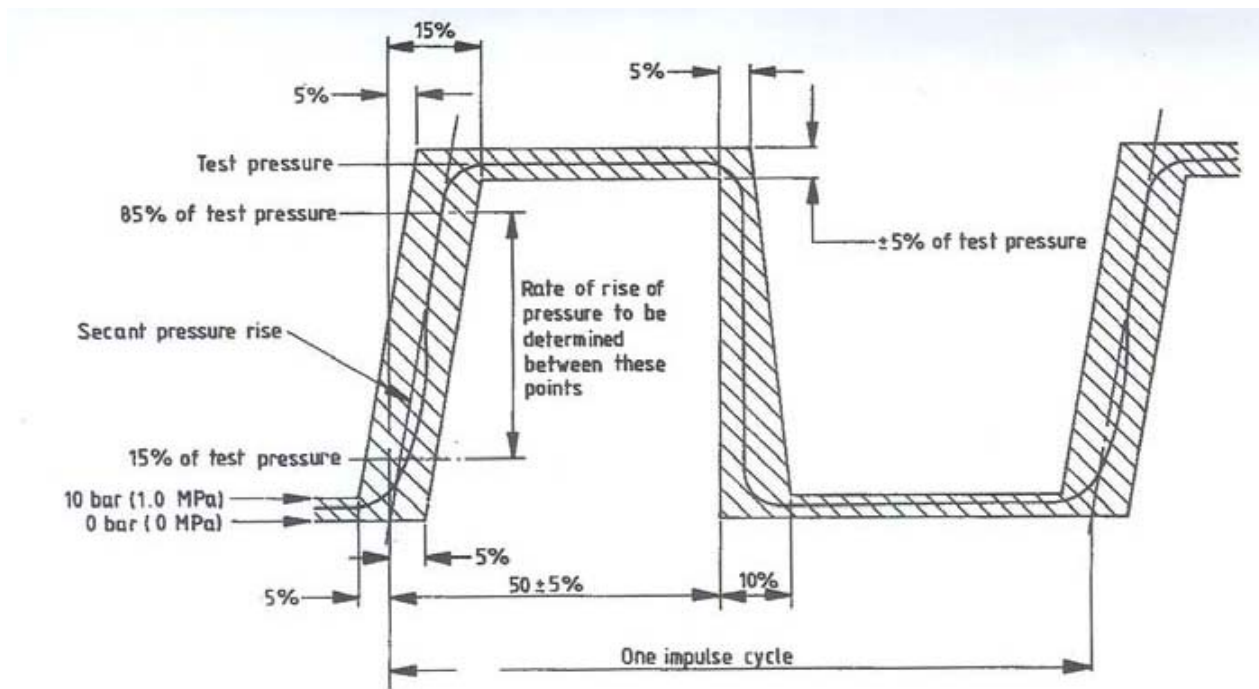

NOTE 1. Rate of rise of impulse test pressure to be between 3000 bar/s and 6000 bar/s.

NOTE 2. Impulse test pressure to equal 1.33 times the maximum working pressure.

Figure 4. Hydraulic impulse test cycle

⁵ Please consult factory for a copy of the report noted

⁶ Laboratory Accreditation Bureau ANS/ISO/IEC 17025-2005 Accredited Lab (www.garwoodlabs.com)

Impulse Test Results:

Fitting Size	Pipe and Fitting Material	Impulse Pressure (PSI/Bar)	Impulse Cycles	Test Result
1/4" NPS	Carbon Steel	6570/453	500,000	Passed No Leakage
1/2" Tube	Carbon Steel	6758/466	500,000	Passed No Leakage
60mm Tube	Carbon Steel	5308/366	500,000	Passed No Leakage
1/4" Tube	Stainless Steel	9251/638	500,000	Passed No Leakage
25mm Tube	Stainless Steel	7527/519	500,000	Passed No Leakage
2" NPS	Stainless Steel	6367/439	500,000	Passed No Leakage
6mm Tube	70/30 CuNi	5598/386	500,000	Passed No Leakage
1/2" NPS	70/30 CuNi	5018/346	500,000	Passed No Leakage
1 1/2" Tube	70/30 CuNi	4820/333	500,000	Passed No Leakage

Vibration Test

Test Report Number	TMI-007 ⁷ (DNV Type Approval Qualification Testing)
Laboratory	Stork Garwood Laboratories Inc. ⁸
Test Parameters	<p>-Each sample is connected to a hydraulic pressure/vibration rig (Fig.2) and static pressure is applied equal to the fittings designed maximum working pressure</p> <p>-While the static pressure is applied vibration put forth on the samples is between 23 Hz and 47 Hz (1380 cycles/min to 2820 cycles/min) and run for a minimum of 20×10^6 cycles (2,000,000 cycles)</p>

Fig.2:

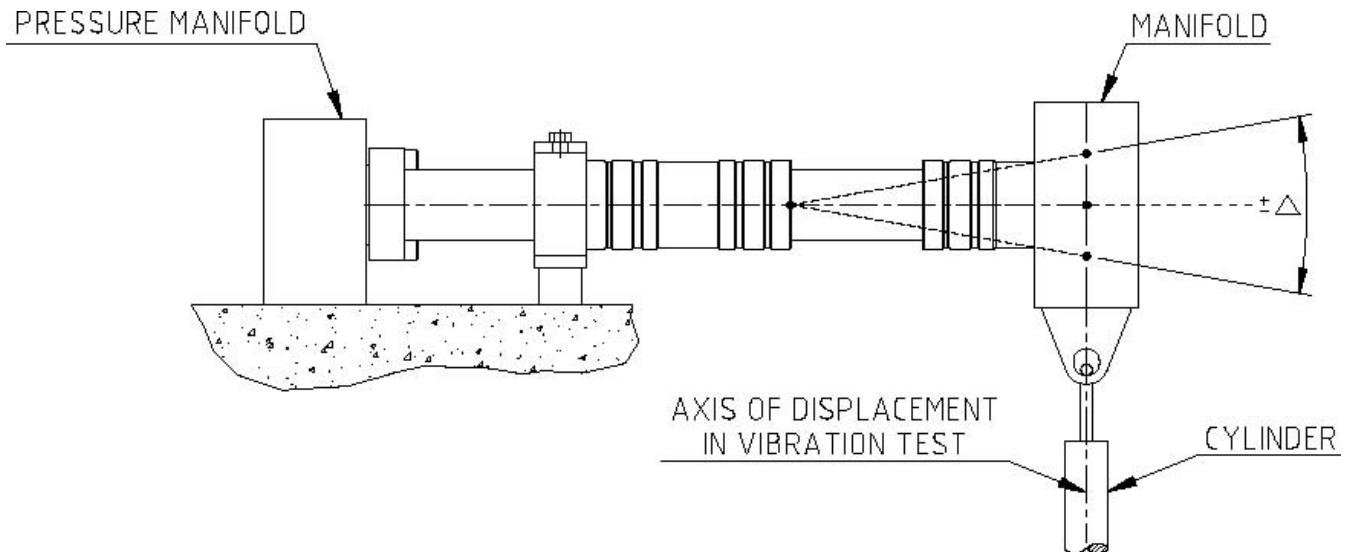

⁷ Please consult factory for a copy of the report noted

⁸ Laboratory Accreditation Bureau ANS/ISO/IEC 17025-2005 Accredited Lab (www.garwoodlabs.com)

Vibration Test Results:

Fitting Size	Pipe and Fitting Material	Static Test Pressure (PSI/BAR)	Frequency (Hz)	Number of Test Cycles	Test Result
1/4" NPS	Carbon Steel	4930/340	46 Hz	20,000,000	Passed, No Leakage
1/2" Tube	Carbon Steel	5075/350	46 Hz	20,000,000	Passed, No Leakage
60mm Tube	Carbon Steel	3988/275	46 Hz	20,000,000	Passed, No Leakage
1/4" Tube	Stainless Steel	6960/480	46 Hz	20,000,000	Passed, No Leakage
25mm Tube	Stainless Steel	5655/390	46 Hz	20,000,000	Passed, No Leakage
2" NPS	Stainless Steel	4785/330	46 Hz	20,000,000	Passed, No Leakage
6mm Tube	70/30 CuNi	4206/290	46 Hz	20,000,000	Passed, No Leakage
1/2" NPS	70/30 CuNi	3771/260	46 Hz	20,000,000	Passed, No Leakage
1 1/2" Tube	70/30 CuNi	3626/250	46 Hz	20,000,000	Passed, No Leakage

Impulse/Flexure and Fatigue at Low Temperature

Test Report Number	MCD-1124 and MCD-1127 ⁹ (Qualification and Certification of Pyplok)
Laboratory	Deutsch Engineering Laboratory ¹⁰
Witnesses	Portions of tests were witnessed by NAVSEA and Long Beach Naval Shipyard Personnel
Test Parameters	<p>-Each Specimen was subjected to a combined cyclic pressure and bending stress where one cycle consisted of pressure increase from 0 psi to 3750 psi back to 0 psi while simultaneously imposing a bend stress from 0 to 60ksi</p> <p>-Eight times during the test at intervals of 10 000 cycles, cycling was interrupted while maximum pressure and bend stress was still being applied</p> <p>-at the interruption point (and while under stress) the test samples were soaked with liquid CO₂ at -100°F for (1) hour and then cycling continued</p> <p>-after cycling each specimen was pressurized to 6000psi and held for 5 minutes</p>

Test Results:

Size (NPS)	Impulse Peak Pressure (PSI/Bar)	Cycle Rate (cpm)	Total Number of Cycles	Proof Test @ 6000 PSI for 5 Minutes	Remarks/Notes
1/4"	3750/260	16	80 919	No Leakage	No leakage or deterioration recorded during test. Specimen has met requirements and passed test.
3/4"	3750/260	14	80 174	No Leakage	
1 1/2"	3750/260	13	82 210	No Leakage	

⁹ Please consult factory for a copy of the report noted

¹⁰ Accredited Lab by NADCAP AS7114 for NDT and Performance Review Institute ISO/IEC 17025 (www.dmcusa.com/aero/supplier-accreditations.lasso)

Tensile Test

Test Report Number	MCD-1124 and MCD-1127 ¹¹ (Qualification and Certification of Pyplok)
Laboratory	Durkee Test Laboratory ¹²
Witnesses	Portions of tests were witnessed by NAVSEA and Long Beach Naval Shipyard Personnel
Test Parameters	-Each sample was installed in a tensile machine with a cross-head speed of ~.20 in/min and then pulled until one side of pipe was dismembered from fitting/pipe joint

Test Results

Size	Tensile Crosshead Speed in/min	Tensile Force Obtained (lbs.)	Remarks
1/4"	0.2	8550 lbs.	Fitting exceeds minimum tensile Pull-out force based on 5 times rated pressure factor
3/4"	0.2	21 700 lbs.	
1 1/2"	0.2	52 700 lbs.	

¹¹ Please consult factory for a copy of the report noted

¹² NADCAP Accredited Laboratory (www.durkeelabs.com)

Torsion Test

Test Report Number	MCD-1141 ¹³ (Qualification Torsion Test for Exxon Chemical America)
Laboratory	Deutsch Engineering Laboratory ¹⁴
Test Parameters	<p>-Each sample was clamped in a vise and on one end torque was applied/measured until a quantifiable slippage was recorded at the fitting/pipe joint</p> <p>-After each sample experienced movement it was then subjected to proof tests with 3750 PSI GN₂ Nitrogen and the 5000 PSI Hydraulic Oil</p> <p>-A burst test followed the proof test where each specimen was subjected to increased pressure until failure</p>

Test Results

Size (NPS)	Applied Torque (Ft. LBS)	Torsion Angle Slippage From 0°	Proof Test 3750 PSI GN ₂ Nitrogen	Proof Test 5000 PSI Hydraulic Oil	Burst Test Failure Pressure	Burst Test Remarks
1/2"	210	32°	No Leakage	No Leakage	25 000 PSI	Pipe ruptured. No leakage was detected prior to failure of the pipe.
1"	933	25°	No Leakage	No Leakage	20 000 PSI	
1 1/2"	1443	10°	No Leakage	No Leakage	14 000 PSI	

Test Summary

The test results surpass the requirements and verify that upon rotational slippage at the fitting/pipe joint, PYPLOK fittings maintain seal integrity.

¹³ Please consult factory for a copy of the report noted

¹⁴ Accredited Lab by NADCAP AS7114 for NDT and Performance Review Institute ISO/IEC 17025 (www.dmcusa.com/aero/supplier-accreditations.lasso)

Heat Aging (168 hour) Test

Test Report Number	MCD-1124 and MCD-1127 ¹⁵ (Qualification and Certification of Pyplok)
Laboratory	Deutsch Engineering Laboratory ¹⁶
Witnesses	Portions of tests were witnessed by NAVSEA and Long Beach Naval Shipyard Personnel
Test Parameters	-Samples were air aged in an oven maintained at a temperature of 400°F (+/- 5°) for 168 hours (7 Days) -After 168 hours (7 Days) of aging each sample was proof tested to 6000 Psi for 30 minutes

Test Results

Size	Aging Hours	Aging Temperature	6000 Psi Proof Test (30 Minutes)	Remarks
1/4"	168 (7 Days)	400°F / 205°C	No Leakage	Samples passed test with no leakage or failure of fitting
3/4"	168 (7 Days)	400°F / 205°C	No Leakage	
1 1/2"	168 (7 Days)	400°F / 205°C	No Leakage	

¹⁵ Please consult factory for a copy of the report noted

¹⁶ Accredited Lab by NADCAP AS7114 for NDT and Performance Review Institute ISO/IEC 17025 (www.dmcusa.com/aero/supplier-accreditations.lasso)

High Impact Shock Test (Mil-S-901D)

Test Report Number	TMI-005 ¹⁷ (Mil-S-901D Shock Test Report)
Laboratory	Stork Garwood Laboratories Inc. ¹⁸
Witnesses	Stork Garwood Engineering Staff
Test Parameters	Mil-S-901D (Grade A, Class 1, Type A, Hull Mounted) -Specimens were mounted to a test fixture which was rigidly attached to the Mil-S-901 Shock Machine -Each specimen was pressurized to maximum designed operating pressure and subjected to a 1, 3 and 5 foot drop on each of the back, top and side axes*

Test Results

Size	Pressure PSI	1 Foot Drop*	3 Foot Drop*	5 Foot Drop*	Remarks/Notes
1/4" OD Tube	6000	Pass	Pass	Pass	No visible damage, leakage or deterioration noted. Fittings pass test requirements.
1/4" Pipe	6000	Pass	Pass	Pass	
1/2" Pipe	5700	Pass	Pass	Pass	
3/4" Pipe	5700	Pass	Pass	Pass	
1 1/2" Pipe	5700	Pass	Pass	Pass	

Test Summary

Samples have met and or exceeded the requirements of the High Impact Shock Test in accordance with Mil-S-901D with no visible evidence of damage or deterioration.

¹⁷ Please consult factory for a copy of the report noted

¹⁸ Laboratory Accreditation Bureau ANS/ISO/IEC 17025-2005 Accredited Lab (www.garwoodlabs.com)

ISO 19921 Fire Test (2005 Ed.)

Test Report Number	TMI-008 ¹⁹
Laboratory	Southwest Research Institute ²⁰
Test Parameters:	<p>-Samples were exposed to a burner that produces temperatures of 800°C (+/- 50°C) below the centre of the assembly for 30 minutes</p> <p>-During the test water circulated through the test sample at 73 Psi at a minimum temperature of 85°C</p> <p>-After fire test each sample was proof tested for 2 minutes</p>

Test Results

Size	Material	Burner Temperature	Proof Pressure 2 Minutes	Remarks
6mm	Copper Nickel	800°C / 1472°F	435 Bar / 6309 PSI	No Leakage detected during 30 minute fire test or during post-fire test proof testing.
1/4" OD Tube	Stainless Steel	800°C / 1472°F	720 Bar / 10 442 PSI	
1/2" OD Tube	Carbon Steel	800°C / 1472°F	631 Bar / 9150 PSI	
1/4" NPS	Carbon Steel	800°C / 1472°F	510 Bar / 7397 PSI	
1/2" NPS	Copper Nickel	800°C / 1472°F	390 Bar / 5656 PSI	
3/4" NPS	Carbon Steel	800°C / 1472°F	500 Bar / 7250 PSI	
1" NPS	Stainless Steel	800°C / 1472°F	590 Bar / 8550 PSI	
1 1/2" OD Tube	Copper Nickel	800°C / 1472°F	370 Bar / 5366 PSI	
2" NPS	Stainless Steel	800°C / 1472°F	495 Bar / 7179 PSI	
60mm	Carbon Steel	800°C / 1472°F	413 Bar / 5990 PSI	

Test Summary

All sample specimens successfully met the entire requirements of the test. No leakage was observed during the fire test or subsequent proof pressure test.

¹⁹ Please consult factory for a copy of the report noted

²⁰ ISO 9001/17025/ 17020 Accredited Laboratory (www.swri.org/EMS/ISO.htm)

API 6FB (3rd Ed.) Fire Test

Test Report Number	TMI-001 and TMI-002 ²¹
Laboratory	Yarmouth Research and Technology ²²
Witnesses	Licensed Professional Engineer (State of Maine)
Test Parameters:	-Conditions were compliant with API 6FB test procedures and requirements

Test Results

Specification: API 6FB, Third Edition, Nov. 1998			
Non-Bending, On-shore or Open-offshore Test			
Seal Area OD:	2.76	Seal Area ID:	2.48 inches
Mean Seal Diameter:	2.48	inches	
Mean Circumference:	7.8	inches	
Allowable Leakage:	7.8	ml/min	
Nominal Test Pressure:	3000	psig	
YRT Technician: Matthew J. Wasielewski, P.E.			
Version of YRT's FIRE-Control 6FB Software: A			
Equipment Confirmed to be in Calibration to NIST Standards: Yes			

Burn and Cool Down Test

Burn Start Time:	15:33:00	
Burn / Cooldown Duration:	60	minutes
Average Pressure During Burn/Cooldown:	3000	psig
Leak Rate During Burn/Cool Down:	0.3	ml/min
Allowable External Leak Rate:	7.8	ml/min
Amount of Time of Avg. Cal. Block > 1200 deg.:	15.8	minutes
Were Test Conditions Within Compliance?	Yes	
Was the Leakage Below the Allowable?	Yes	

Depressurization - Re-pressurization Test

Average Pressure During Test:	3020	psig
Gasket Leak Rate:	0	ml/min
Allowable External Leak Rate:	7.8	ml/min
Was the Leakage Below the Allowable?	Yes	

Does the Coupling Pass or Fail API 6FB? **PASS**

Witnesses

Matthew J. Wasielewski



²¹ Please consult factory for a copy of the full report noted

²² All tests performed and certified by a Professional Engineer to meet ISO 9001 requirements (www.yarmouthresearch.com)

Test Results (Cont.)

Specification: API 6FB, Third Edition, Nov. 1998				
Non-Bending, On-shore or Open-offshore Test				
Seal Area OD:	1.42	Seal Area ID:	1.21	inches
Mean Seal Diameter:	1.21			
Mean Circumference:	3.8			
Allowable Leakage:	3.8			
Nominal Test Pressure:	3589			
YRT Technician: Matthew J. Wasielewski, P.E.				
Version of YRT's FIRE-Control 6FB Software: A				
Equipment Confirmed to be in Calibration to NIST Standards: Yes				

Burn and Cool Down Test

Burn Start Time:	15:15:00	
Burn / Cooldown Duration:	60	minutes
Average Pressure During Burn/Cooldown:	3534	psig
Leak Rate During Burn/Cool Down:	0.5	ml/min
Allowable External Leak Rate:	3.8	ml/min
Amount of Time of Avg. Cal. Block > 1200 deg.:	17.0	minutes
Were Test Conditions Within Compliance?	Yes	
Was the Leakage Below the Allowable?	Yes	

Depressurization - Repressurization Test

Average Pressure During Test:	3597	psig
Gasket Leak Rate:	0	ml/min
Allowable External Leak Rate:	3.8	ml/min
Was the Leakage Below the Allowable?	Yes	

Does the Coupling Pass or Fail API 6FB? | PASS

Witnesses

Matthew J. Wasielewski



PYPLOK Qualification Test Reports

Report No.	Rev. No.	Report Title and Discription	Report Date
MCD-1054	-	Qualification Test of Deutsch Marine Fittings on Corrosion Resistant Steel and Copper-Nickel Alloy Pipes for Shipboard Hydraulic Systems.	Jul-79
MCD-1055	-	Qualification Test of Deutsch Marine Fittings on Corrosion Resistant Steel and Copper-Nickel Alloy Pipes for Shipboard Pneumatic Systems.	Jul-79
MCD-1056	-	Qualification Test of Deutsch Marine Fittings on Copper-Nickel Alloy Pipes for Shipboard Sea Water Systems.	Jul-79
MCD-1069	-	Qualification Test on 12 mm Deutsch PypLok Cres Fitting on Cres Pipes	Oct-80
MCD-1071	-	Qualification of Deutsch MCD 1-1/2 IPS PypLok Fitting DM10001B24 (Cu Ni) and DM10001K24 (Cres) on Corrosion Resistant Steel Pipe, Carbon Steel Pipe, Copper Nickel Pipe for Shipboard Hydraulic Systems.	Dec-80
MCD-1072	-	Qualification of Deutsch MCD 1-1/2 IPS PypLok Fitting DM10001B24 (Cu Ni) and DM10001K24 (Cres) on Corrosion Resistant Steel Pipe, Carbon Steel Pipe, Copper Nickel Pipe for Shipboard Pneumatic Systems.	Jan-81
MCD-1073	-	Qualification of Deutsch MCD 1-1/2 IPS PypLok Fitting DM10001B24 on Copper Nickel Alloy Pipes for Shipboard Sea Water System	Dec-80
MCD-1087	-	Tensile Pull-Out Strength of Deutsch MCD 1-1/2 IPS PypLok Fitting DM10001B24 (Cu Ni) and DM10001K24 (Cres) on Corrosion Resistant Steel Pipe, Carbon Steel Pipe, Copper Nickel Pipe for Shipboard Systems.	Apr-81
MCD-1109	-	Qualification of Deutsch MCD ¼" Through ¾" I.P.S. Carbon Steel PypLok Fitting (3000 psi)	Jul-82
MCD-1110	-	Corrosion Test for Coated Carbon Steel PypLok Fitting	Jun-82
MCD-1118	-	Preliminary Qualification and Certification of Nikko-Deutsch 41mm PypLok Fitting for 230 psi Shipboard steam system for Ishikawajima-Harima Heavy Industries Company (I.H.I)	Nov-82
MCD-1122	-	Qualification and Certification of Nikko-Deutsch 41mm PypLok Fitting for 230 psi Shipboard steam system for Ishikawajima-Harima Heavy Industries Company (I.H.I)	Feb-83
MCD-1124	-	Qualification and Certification of ¼" O.D. Through ¾" N.P.S. Fittings PypLok Cres 316L (3750 psi), 400 °F Maximum	Dec-83

MCD-1126	-	Qualification and Certification Dry Fire Testing of ¼" O.D. Through ¾" N.P.S. Fittings PypLok Cres 316L (3750 psi), 400 °F Maximum	Dec-83
MCD-1127	-	Qualification and Certification of 1-¼" O.D. Through 1-1/2" N.P.S. Fittings PypLok Cres 316L (3750 psi), 400 °F Maximum	Dec-83
MCD-1130	-	Life Test of PypLok 70-30 CuNi Fitting Assemblies Sizes ¼" O.D. Through ¾" N.P.S. for Naval Shipboard Air Conditioning and Refrigeration Applications	Aug-86
MCD-1133	-	Qualification and Certification Dry Fire Testing of 1-¼" O.D. Through 1-1/2" N.P.S. Fittings PypLok Cres 316L (3000 psi), 400 °F Maximum	Sep-83
MCD-1141		Qualification of Torsion Test of Deutsch PypLok Fitting Sizes ½", 1", and 1-1/2" N.P.S 3750 psi for Exxon Chemical American.	Jul-84
MCD-1172	A	Deutsch PypLok DLP Series 70-30 CuNi Fittings (600 psi) 400 °F Maximum, Sizes Up to 2-1/2" N.P.S. or 2.875" O.D. on CuNi (70-30 and 90-10) Class 200 per MIL-T-16420 and Copper Piping per MIL-T-24107.	Aug-88
MCD-1203	-	Deutsch PypLok 70-30 CuNi Fittings ¼" O.D. Gageline Tailpiece 3750 psi, 400 °F Maximum	Jun-89
DMC-1221	-	Test Report Deutsch PypLok DM Series Fittings-Cres and PypLok Inserts-Cres, on Carbon and Stainless Steel Piping, Sizes up to 1-1/2" NPS, 3750 psi Maximum Working Pressure.	Sep-90
DMC-1242	-	Qualification Test Report Deutsch PypLok DM Series Fittings and PypLok Cres Inserts on Carbon and Stainless Steel Piping; Sizes up to 1-1/2" NPS, 3750 psi Maximum Working Pressure, 600 °F Maximum Working Temperature.	Feb-92
DMC-1254	-	Proof and Burst Testing of Deutsch PypLok DM Series Cres Fitting on 1" NPS Schedule 40 6061-T6 Aluminum Pipe.	May-92
DMC-1271	A	Pressure Qualification of PypLok (DM & DP Series) Fittings In Accordance With ASME B31.1 & B31.3	Dec-99
DMC-1279	-	Discussion of The Vacuum Capability of PypLok Fittings	Oct-92
DMC-1318	B	Pressure and Torsion Qualification of DP40 Series PypLok In Accordance With Dupont Requirements	Jan-98
DMC-1354	-	Test Report Deutsch DP40 PypLok, Fire Test Per API 607 Fourth Edition	Oct-94
DMC-1362	A	Pressure Qualification of DP40 Series PypLok Fittings In Accordance With ASME B31.1 & B31.3	Jan-98
DMC-1383	-	DP40 PypLok Application Suitable for Use on Copper-Nickel Pipe BS2871 Metric Applications Up to 88.9 mm	Nov-94
DMC-1430	-	DM Series PypLok Burst Test Performance for Tube-Mac on Stainless and Carbon Steel Pipe, Sizes ½" - 1 1/2" NPS	Jan-97

DMC-1452	-	Proof and Burst Testing of Deutsch PypLok DM Series Cres and Carbon Steel ¾", 1", and 1-1/2" NPS Fittings on ASTM A106 Gr. B, Schedule 160 Pipe.	Oct-97
DMC-1488	-	Proof and Burst Test on DPM Series PypLok for Tube-Mac, Sizes ¼" NPS to 2" NPS, 56mm and 66mm Stainless Steel Fitting on Stainless and Carbon Steel Pipes	Jul-98
DMC-1492	-	Pressure Qualification of DPM Series PypLok Fittings In Accordance With ASME 31.4 & ANSI 31.8	Oct-98
DMC-1493	-	Proof and Burst Test on DTM Series Hyda-Crimp Fittings for Tube-Mac, Sizes 1/2" NPS to 2" NPS, 56mm and 66mm Stainless Steel Fitting on Tube-Mac Provided Carbon Steel Pipes	Oct-98
DMC-1499	-	Proof and Burst Test on DPM Series PypLok Sizes ¼" NPS Through 2" NPS Stainless Steel Fitting on Stainless and Carbon Steel Pipes.	Nov-98
DMC-1503		Proof Test 2" NPS DPM Series Carbon Steel PypLok Fitting with Kerosene Media at -60 °F In Accordance with ASME B31.4 Specification.	Feb-99
DMC-1518	-	Deutsch PypLok DP40 Series Pipe Fitting Test for Suitability for Use in Esso Off-Shore BS2871 Copper-Nickel Pipe Work Systems.	Dec-94
DMC-1521	-	Test Result Comparison of 1" NPS and 2" NPS DP40 Carbon Steel PypLok Fittings with Broached Teeth Vs. Knurling.	Jun-99
DMC-1523	-	Proof Test of 2" NPS DP40 Series Carbon Steel PypLok Fitting In accordance with ASME B 31.8 Specification.	May-99
DMC-1525	-	Proof, Burst, and Tensile Tests on DP40 Series Carbon Steel PypLok 2" NPS Fitting on Polyethylene Pipe	Jun-99
TMI-001	-	API 6FB Fire Test on DM Series 2" NPS Carbon Pyplok (DM Series Pyplok)	Jan-08
TMI-002	-	API 6FB Fire Test on DM Series 3/4" NPS Carbon Pyplok (DM Series Pyplok)	Jan-08
TMI-003	-	Pressure and Bend Testing of DM Series Pyplok and Threaded Couplings for NPS 1 ½", Schedule 80 Pipe	Aug-08
TMI-004	-	CRN Burst and Proof Testing of DM Series Pyplok (Carbon and Stainless)	Mar-08
TMI-005	-	Mil-S-901D Shock Test for DM Series Pyplok (Stainless Steel and 70/30 CuNi)	Feb-08
TMI-006		Proof performance testing 2" Carbon Pyplok (DM20001G32) on Galvanized 2" Sch.40 Pipe	May-08
TMI-007	-	DNV Type Approval Qualification Testing for Carbon and Stainless DM Series Pyplok (Proof, Burst, Gas Leakage, Impulse and Vibration Tests)	Jul-09

TMI-008	-	ISO 19 921 Test, 2005 Ed. Ships and Marine Technology – Fire Resistance of Metallic Pipe Components with Resilient and Elastomeric Seals – Test Method (Functionally Equivalent to ISO 15 540 Fire Test 2001 Ed. Ships and Marine Technology- Fire Resistance of Hose Assemblies – Test Method)	Apr-08
TMI-009	-	2" PYPLOK Proof, Bend and Burst Test on Sch.10 316L Pipe for Esso / Exxon On-Shore and Off-Shore applications	Sep-09
TMI-010	-	3" PYPLOK Qualification Test Report	Nov-08
TMI-011		TBA	
TMI-012		TBA	

For more information regarding PYPLOK® please visit www.pyplok.com or call your local area representative.

